CHAPTER 4

New Mexico State University
College of Engineering
Department of Mechanical Engineering
Las Cruces, New Mexico 88003

Principal Investigators:

Raymond A. Willem (505)646-2117

"Accessible Work-Holder"
A Wheelchair Accessible Work-Holder
for Shop Use

Designers: D. A. Aden, G. L. Leshikar, M. A. Md. Ali
Disabled Coordinator: Jim Thompson, Las Cruces Public Schools
Supervising Professor: R. A. Willem, Ph.D.
Mechanical Engineering Department
New Mexico State University
Las Cruces, NM 88003

INTRODUCTION

In a workshop setting, a person in a wheelchair often has difficulty in fully accessing a work piece for drilling, painting, sanding or other operation. Many work benches have a skirt, lower shelf or inconveniently placed legs that do not allow convenient wheelchair access.

The Accessible Work-Holder has been developed to satisfy this need. It provides two stations where different types of clamping devices may be located – perhaps a toggle clamp on one and a vise on the other. The work stations are located at opposite points of a diamond-shaped frame while the frame is supported by columns at the other two points of the diamond as shown in the photo. Therefore, this design eliminates any obstructions below the work station and provides more than 270° of access in the horizontal plane. The work stations can be adjusted in height by moving the frame vertically on the supporting columns. The work piece can be rotated about a horizontal axis and tilted in almost any direction by means of locking ball-joints to which the toggle clamp and vise are each mounted.

SUMMARY OF IMPACT

The student for whom this was designed is a paraplegic who is mentally, as well as physically, disabled. The student has found the Accessible Work-Holder to add to the ease of doing certain kinds of shop work and it appears to promote more work with less fatigue. Also, tasks that could not be performed previously are now possible due to the improved accessibility and convenience provided by this device.

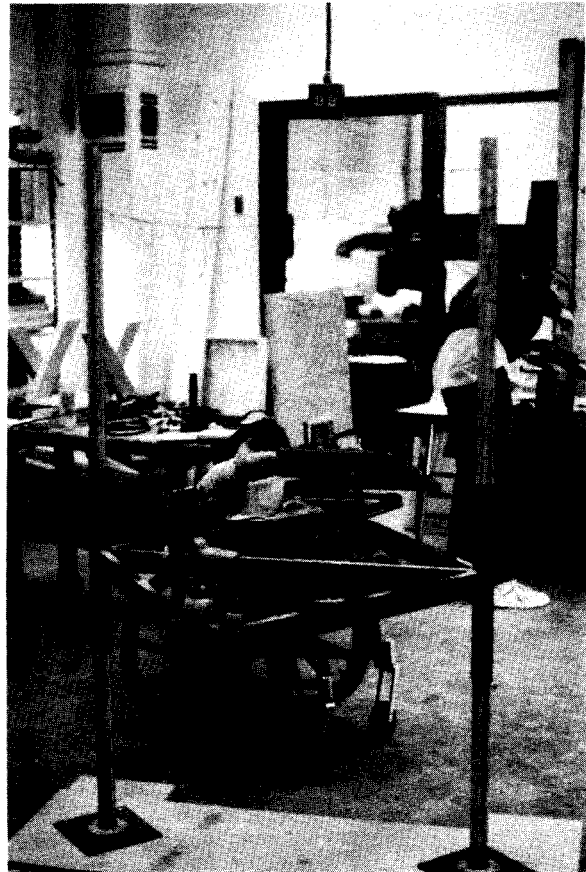

TECHNICAL DESCRIPTION

The accessible Work-Holder is shown below in its basic form. The diamond shaped frame has dimensions across its opposite points of 36 x 48 inches. At the points where the work stations are located, the lengths of steel channel are welded to short pieces of steel tubing. These pieces of tubing provide a seat for the shank of a platform (as shown in the drawing) or locking ball-joint (as shown in the photograph). In either case, the shank is locked to the seat by a hand screw.

At the other two opposite points of the diamond shaped frame, the three pieces of channel joining at those points are welded to 18 inch lengths of steel pipe called collars. These collars are an integral part of

the frame and provide the locating surface for moving the frame vertically on the columns.

The frame is positioned vertically by placing a nut and bolt in the appropriate thru-hole in each column that will maintain the frame at the desired height. The holes in the columns (but not the nuts and bolts) are shown in the drawing.

Finally, it is necessary to attach the columns solidly to a base so that they are parallel to each other. In this case, a wood base was used. The vise, toggle clamp and locking ball-joints are purchased items. The approximate cost to build this device is \$500.

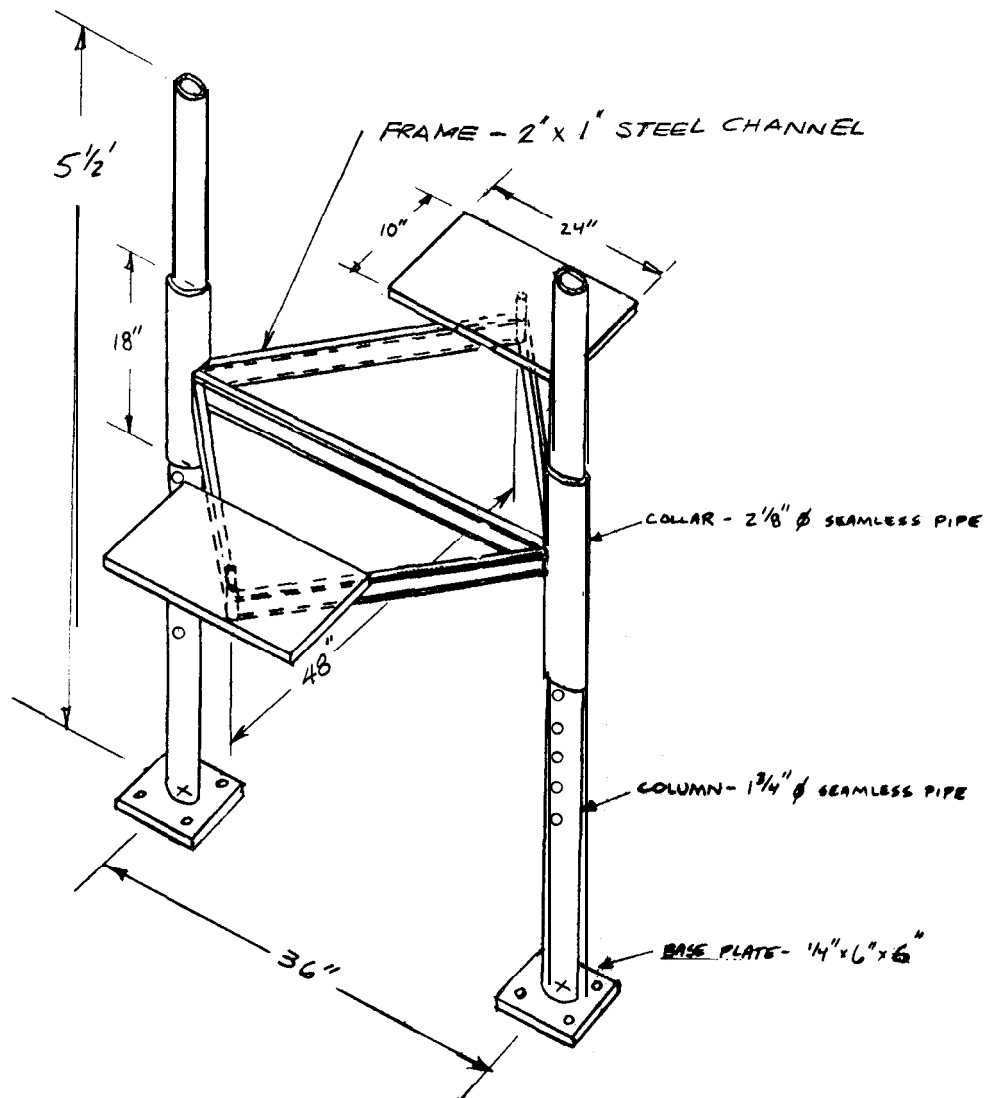

"Multipurpose Desk for a Quadriplegic Engineer"

Designer: Ram B. N. Prasad
Disabled Coordinator: E. J. Hoskins, M.D., Ph.D.
Supervising Professor: R. A. Willem, Ph.D.
Mechanical Engineering Department
New Mexico State University
Las Cruces, NM 88003

INTRODUCTION

A desk was designed and fabricated which met the needs of a specific quadriplegic engineering student who was soon to graduate. In addition to meeting his professional needs, the desk also had to be convenient to move when the student relocated after graduation.

The desk had to provide an accessible computer work station, writing area and book storage area and all of these areas had to be easily accessible from one another. While performing these various functions, the desk also had to be relatively compact and, as already mentioned, easy to move.

To provide for accessibility, the desk is totally supported along its ends and back edges thus removing all underneath obstructions. Compactness is achieved by using an L-shaped design for corner placement, locating the computer keyboard on a sliding tray and making good use of the corner of the L by placing the printer and paper supply in that location. The book storage is made accessible by placing it forward on the desk, in front of a storage area which, unfortunately, is not accessible by the student.

The vertical surfaces are connected to one another by piano hinges. The desk may be disassembled by removing a few screws connecting the horizontal with the vertical surfaces and then folding the vertical surfaces along the piano hinges.

SUMMARY OF IMPACT

The designer of this desk, himself a student, spent a large amount of time with the quadriplegic recipient while obtaining design information. Also, as the concept for the desk evolved, the student recipient was kept informed and asked for input. As a result, the recipient was aware of the general design when fabrication began. However, he was obviously surprised and delighted at how very well the completed desk met his needs. In addition, he found it aesthetically very pleasing.



TECHNICAL DESCRIPTION

The basic material used was $\frac{3}{4}$ inch medium density particle board with an oak veneer. The desk working surfaces were covered with a high pressure laminate. The shelf for the printer paper supply (1) can be lifted off the desk and the supporting brackets folded under. The approximate cost of making this desk was \$950.

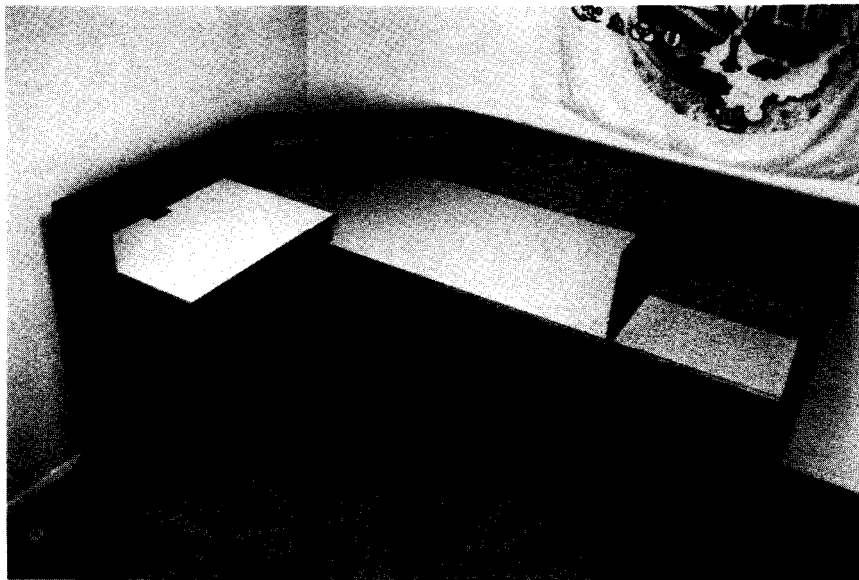
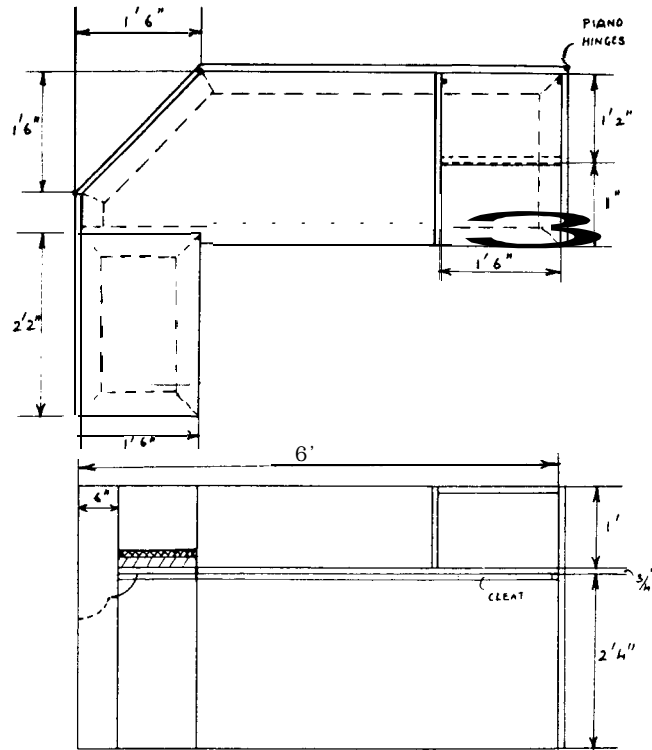

"A Special Desk for a Special Student"

Designers: M. Mackie, E. Erpenbeck, M. Al-Quidahi
Disabled Coordinator: A. Curtis, Las Cruces Public Schools
Supervising Professor: R. A. Willem, Ph.D.
Mechanical Engineering Department
New Mexico State University
Las Cruces, NM 88003

INTRODUCTION

A sixth grade boy in the Las Cruces Public Schools was born without arms and with one leg three inches shorter than the other. He has adapted well to his handicap. For example, he has learned to write with his foot-by gripping a pencil or pen between his toes. He is able to attend regular school without great difficulty, but among his disadvantages was his inability to use a regular school desk. He wrote by sitting on one chair while writing on the seat of another chair facing toward him, a rather inadequate situation.

A student design group, after studying the problem in depth, designed a desk specifically to meet the needs of this student. Among its features are a writing surface at an optimum height and angle. The writing surface has a mat finish which inhibits slipping of the paper. Also, the desk has two drawers and a sliding bookshelf which have been designed to be accessible by the student.

SUMMARY OF IMPACT

The handicapped student was pleased with the desk from the beginning. The convenience and pleasure that it has added to his performance of school tasks – reading as well as writing – is evident. He is now able to sit in a comfortable position when doing school work and he has space in the drawers and bookshelf to store his things. He feels sufficiently attached to the desk that it troubles him when his homeroom teacher allows other students to use the desk.



TECHNICAL DESCRIPTION

The drawing below gives the essential details of the desk. The basic material for the desk is $\frac{1}{2}$ inch plywood. Using the dimensions shown produces a writing surface angle with the horizontal of 18° . The drawer pulls were selected to be easily pulled by foot. In spite of the depth of the lower front drawer, it is fully accessible by the student. What appears to be a drawer in the side of the desk is not a drawer but a sliding bookshelf. It is similar to a drawer in design but has the side facing toward the front of the desk missing. In that way, books can be accessed easily by the student while sitting in front of the desk.

The cost of making this desk was approximately \$375.

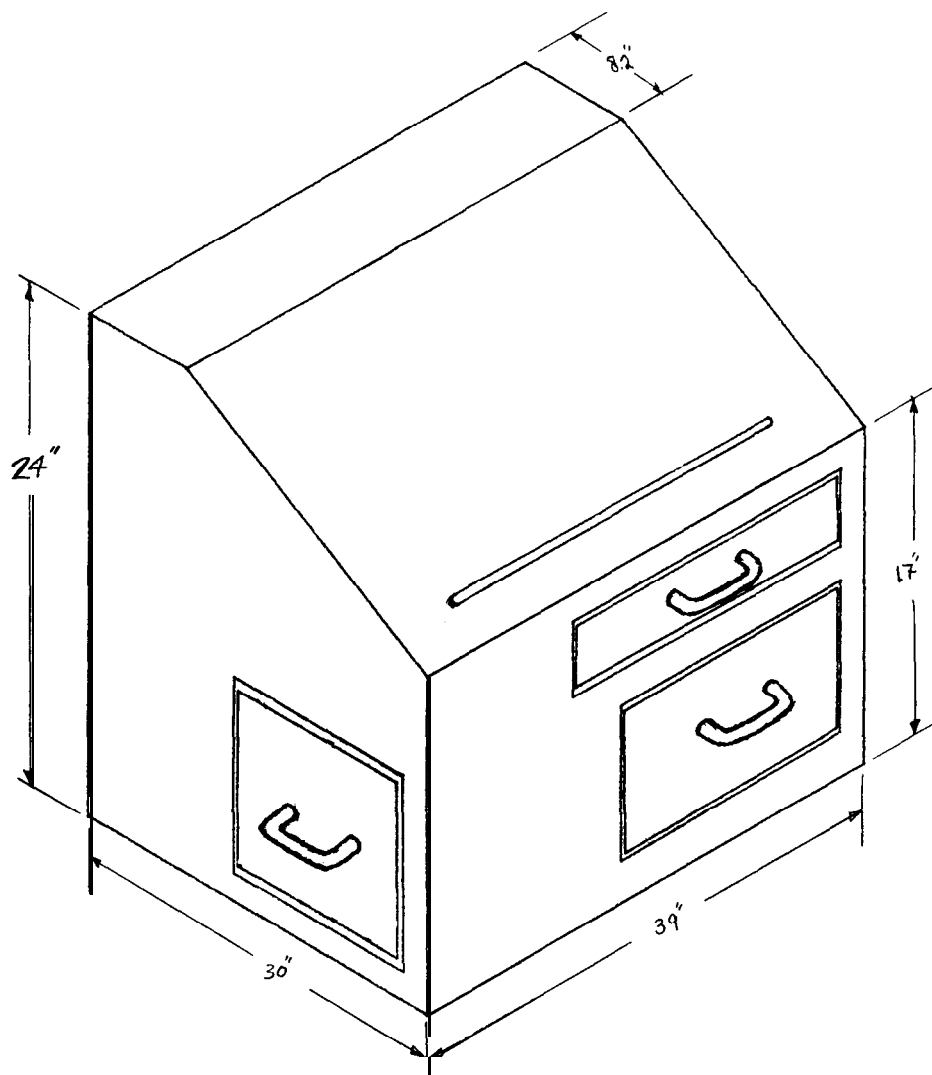

"A Motion Activated Toy"

Designers: S. Owen, V. Assai
Disabled Coordinator: M. Dawson, Las Cruces Public Schools
Supervising Professor: R. A. Willem, Ph.D.
Mechanical Engineering Department
New Mexico State University
Las Cruces, NM 88003

INTRODUCTION

A girl in the Las Cruces School System of about 5 years of age is seriously mentally and physically handicapped. She is able to hit a dangling object while lying on her side, however, she often lacks motivation to do this. It was thought that her action of striking a dangling object could be made to operate a battery operated toy for some short period of time and, thus, provide her with additional motivation. Also, it would help her develop the idea of "cause and effect".

The problem required that a dangling object be presented to the child in a safe and aesthetic fashion. When the object is struck lightly in any manner, this should have the effect of turning on a battery operated toy for some period of time between 10 and 30 seconds. These goals were achieved with a system that suspends a tennis ball from a cord in an easily struck position. Motion of the tennis ball causes an array of mercury switches located at another point on the cord to momentarily close a circuit. This activates a timer model and allows a battery operated toy to operate for a predetermined period.

SUMMARY OF IMPACT

It required some time to introduce the child to the device and to develop consciousness of the ball and toy simultaneously. It appeared after time, however, that the child did develop some connection between the two events.

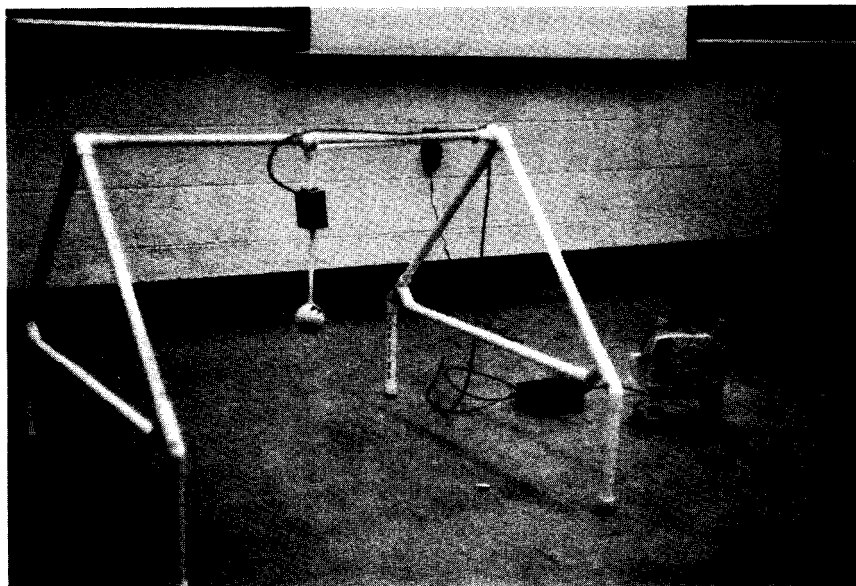

TECHNICAL DESCRIPTION

The frame for **suspending** the tennis ball and switch (see photo.) is **made of polyethylene** pipe and fittings. The **tennis ball** is **suspended** by a nylon cord **which** also supports an aluminum box **containing** three mercury switches. The mercury switches are connected in parallel with one another so that closure of any one or combination of switches will activate the timer module. The three switches are oriented so that any small angular displacement will cause at least one of the switches to close.

The original timer module was designed by the students and was operated from a **9V** AC to DC converter. This timer, however, developed reliability problems after some time and it **is** planned to replace it with a ready-made module (likely one marketed by Steven Kanor, Ph.D. Inc. of Hastings, NY).

The timer module closes the circuit of the battery operated toy. However, the timer module **only** provides the switching function for the toy. The **power** for the toy is **supplied** by batteries housed in the toy. The timer **module is introduced** into the electrical **circuit** of the toy by means of a battery interrupter, a device composed of a cable with a jack on one end which plugs into the timer module and a disc on the other end. The disc is a laminate of two metallic outer wafers separated by a wafer of insulation. When slipped between two batteries, the disc insulates the batteries from each other and allows the circuit to be switched at the jack.

The cost of making this device using the purchased timer module and not including the toy is approximately \$80.

"Wheelchair Placement in Car Mechanism"

Designers: J. R. Sanders, W. J. Wilson, A. S. Siraj
Supervising Professor: R. A. Willem, Ph.D.
Mechanical Engineering Department
New Mexico State University
Las Cruces, NM 88003

INTRODUCTION

This device is to assist a paraplegic with limited upper body strength in placing a wheelchair on the passenger side of the front seat of a car. The device is **portable** and is hung from the rain gutter on the front passenger side of the car before each use. It is **electrically powered** from the cigarette lighter socket and is operated by a hand held controller that contains a forward-reverse switch and an on-off button which turns off when released.

To use it, the person transfers from the wheelchair to the passenger front seat. After placing the device on the rain gutter and plugging it into the cigarette lighter socket, the caster wheels of the folded wheelchair are raised and placed inside the door sill. Then the **spool**

on which the strap is wound is disengaged from its shaft by sliding the spool toward the front of the car. Sufficient strap is reeled off the spool to allow the end loop to be placed over the push handles of the wheelchair. The spool is reengaged with the shaft by sliding it rearward and with the switch in the forward position, power is applied by depressing the on-off button. As the wheelchair is pulled into the car, it is necessary to guide its motion. Once in the car, the loop is removed from the push handles and the free strap is wound back onto the spool and the device is stowed.

SUMMARY OF IMPACT

The paraplegic user finds that this device avoids the need of struggling to get a 40 lb. wheelchair into his car. As a result of its lightness, compactness and *good* design, he also finds it remarkably convenient to use.



TECHNICAL DESCRIPTION

The Wheelchair Placement in Car Mechanism weighs 4 lbs. and has over all dimensions of 3.0 x 4.8 x 4.8 in. The heart of the device is the 12 volt Model 42837 ($\frac{1}{90}$ HP) Dayton Gearmotor rated at 40 in-lb with a 191.6:1 gear reduction and 12 rpm speed. The motor drives the spool shaft through a 1:1 miniature chain drive enclosed by the cover on the left end. The spool shaft rotates in plain bronze bushings pressed into the inverted U-shaped frame. The axial position of the spool shaft is maintained by the two collars enclosing the bearing on the right side. The spool is made of aluminum and has two positions on the shaft. The spool is shown in the driving position in which a slot in the left end of the spool engages a shaft pin. The spool is maintained in this position by means of a spring loaded ball in the spool engaging a circular groove in the shaft. The spool becomes free-wheeling when moved from the position shown to the right end of the shaft.

An electrical connector for the motor is mounted in the frame and provides a connecting point for the wire going to the control box and cigarette lighter plug-in. The cost to make this device is approximately \$500.

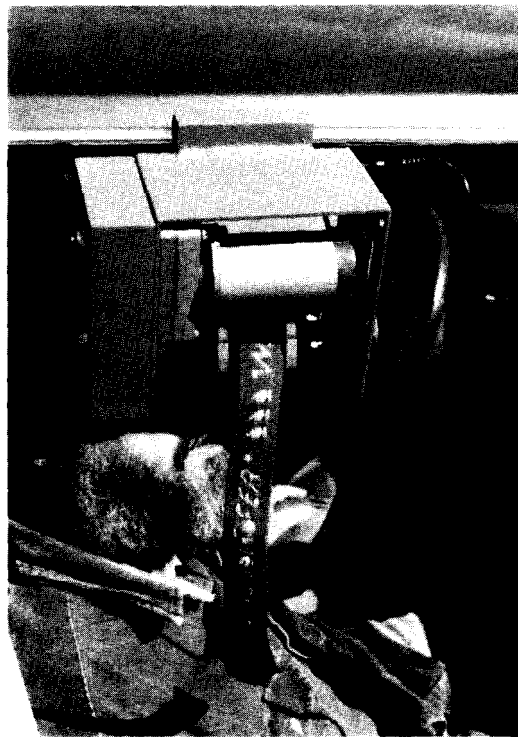

"Folding Cane for the Sight Impaired"

Designers: P. Zeman, T. Borland, A. Abdaljabbar
Supervising Professor: R. A. Willem, Ph.D.
Mechanical Engineering Department
New Mexico State University
Las Cruces, NM 88003

INTRODUCTION

The sight-impaired often use a cane to assist in finding their way around. The single-piece fiberglass cane is very popular because it is light weight and relatively flexible. These characteristics contribute to its ease-of-use and sensitivity in determining the nature of the terrain. Canes which have multiple pieces and are foldable or collapsible have the advantage of being compact when not in use but at the same time become more heavy and stiff and, therefore, have diminished effectiveness in performing their principal function.

The goal of this project was to develop a cane that could be easily compacted and reassembled by a blind person and which was approximately as easy to use and effective as a single piece cane.

SUMMARY OF IMPACT

This project was undertaken to assist a *sight*-impaired female university student. She wanted a cane that could be compacted to a size that would fit in a large hand bag yet would be approximately as effective as the single piece cane. This would avoid the problem of having to lay the cane on the floor when not in use and having passersby trip or step on it.

The recipient of the cane finds it totally successful in meeting its objectives. Not only does it feel essentially like the single piece cane from which it is constructed but it can be folded or reassembled in 5 seconds with little difficulty.

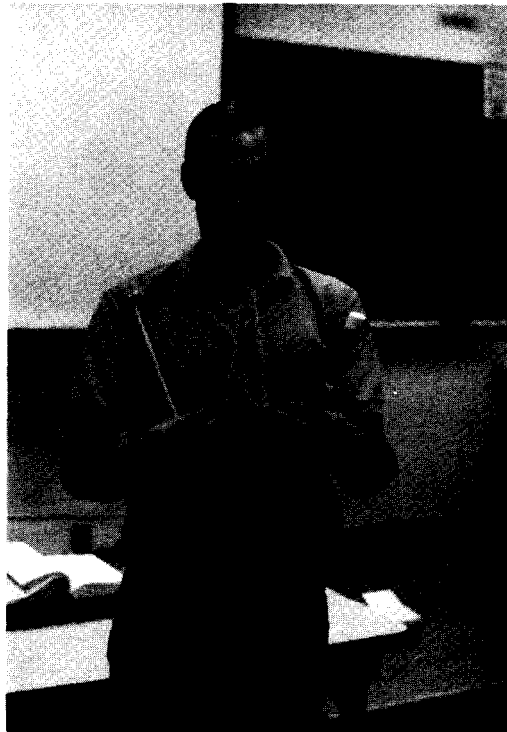

TECHNICAL DESCRIPTION

The principle component in fabricating this cane is a standard tapered fiberglass cane with a rubber-mounted metal tip. This can is cut into four approximately equal pieces. Then the handle portion on the largest diameter piece is cut off making the part that remains relatively short.

Three joints of the design shown are machined to join the four pieces. Note that each joint is a different size since the original cane was tapered. The fit between the two aluminum pieces of each joint must be snug to avoid mechanical looseness in the finished cane. The joints are fixed in the ends of the fiberglass pieces with epoxy. The large end of the short fiberglass section is epoxyed into the handle as indicated on the handle drawing.

Teflon-coated, 50 pound test nylon fishing line has been used to thread the four sections together and always maintain them in their proper order. When the cane is in its extended configuration, it is the line under tension that pulls the cane sections together.

Final assembly of the cane sections is achieved by taking an eight foot length of fishing line and tying a small helical tension spring to one end. With the handle end cap removed, the outer handle tube section (without the pin in place) can be assembled over the inner tube. Then the pin is placed into the outer tube so that it engages the pin guide in the inner tube and also catches the free end of the helical spring (with line) which has been placed inside of the inner tube. The line (attached to the other end of the spring) is then threaded through the other cane sections and will be anchored in the inside of the tip section. The line is cut to length and anchored so that when the pin (in the handle) is at the bottom of the pin guide and the sections are unjoined (the condition in the photograph), the line is extended but without tension.

To put the cane into its extended configuration from the compact configuration, the cane is allowed to hang down while being held with one hand by the black part of the handle (outer tube). Then with the other hand, the inner tube is pushed into the outer tube and rotated. This causes the pin to rise into the inverted-J portion of the guide slot and locks the cane in the extended configuration.

The cost of fabricating this cane was \$4.00 including machining time.

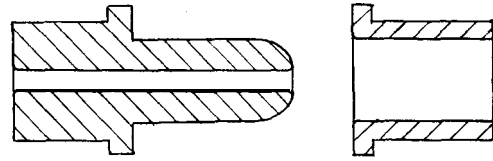

TWO PIECE JOINT (ALUM.)

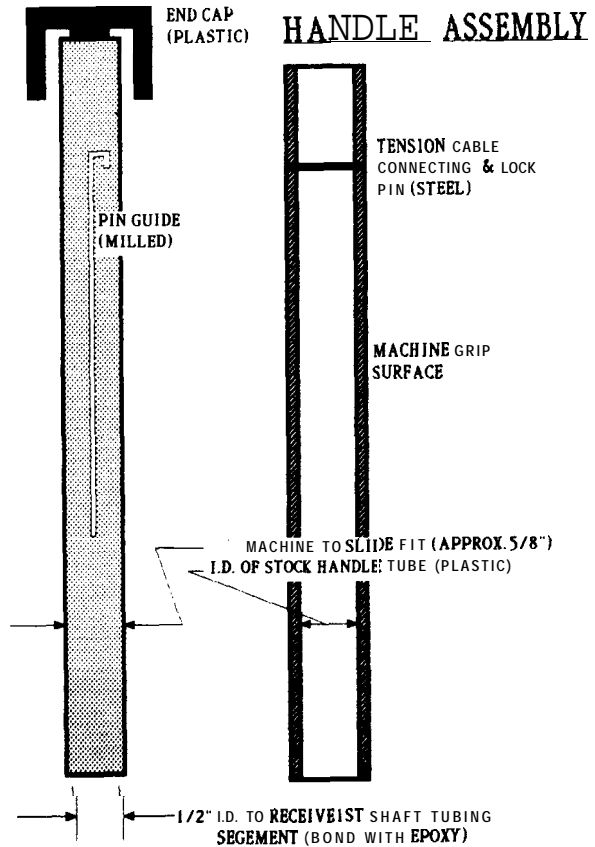

"Voice Loudness Indicator"

Designers: J. Ruiloba, H. Ottenhoff
Disabled Coordinator: N. Lowe, Las Cruces Public Schools
Supervising Professor: R. Black
Electrical and Computer Engineering Department
New Mexico State University
Las Cruces, NM 88003

INTRODUCTION

The Voice Loudness Indicator monitors voice loudness and activates a red, green or amber light depending on whether the voice is too loud, sufficiently loud, or too low, respectively. It has a gain control which permits adjustments to compensate for the placement of the device relative to the speaker.

In use, the device is placed so that the sloping front panel containing the lights and the microphone is facing the speaker. After an initial gain adjustment, the speaker can then use the device to help him/her moderate their voice. On the back side of the device is an LED array which allows the person facing the speaker (speech pathologist perhaps) to also monitor the loudness indication.

SUMMARY OF IMPACT

The client is an eighteen year old boy who is multiply impaired with autistic tendencies. He has prosody of speech (rhythm and intonation) problems which leads to difficulty in controlling speech loudness. His tendency is to shout.

He has taken enthusiastically to using the device and it has had a marked effect in reducing the loudness level without voice distortion. It has also made him somewhat conscious of maintaining a moderate voice level when not using the device.

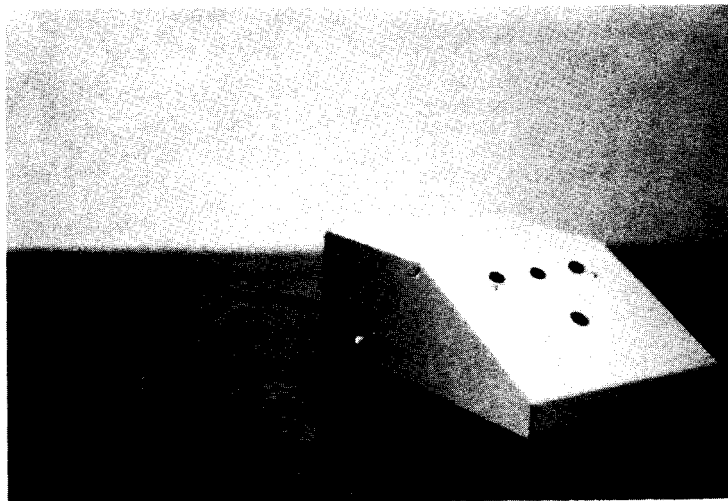

"Accessible Door Closer"

Designers: R. Mackintosh, A. Morales, A. Haji Abdul
Handicapped Coordinator: D. Koehner, New Vistas Center
Supervising Professor: R. A. Willem, Ph.D.
Mechanical Engineering Department
New Mexico State University
Las Cruces, NM 88003

INTRODUCTION

It is often difficult for a person in a wheelchair to close a door that they have just passed through. This is particularly true when the door opens into the room that the person is leaving.

A simple device for solving this problem has been devised. It consists of a door hinge with a torsional spring bias such as is used on screen doors to maintain them in a closed position. This item, easily found in hardware stores, is on the back side of the door and, therefore, is not visible in the photo below. A simple hinge of this design, when installed on a light door; is sufficient to slowly move the door to the closed position.

When the horizontal slide (with the two knobs) is in its leftward position, the door will be held open to whatever extent it has been pushed open. The slide is put in this position by a person in a wheelchair before passing through a door. This will hold the door and allow unobstructed passage. Then, after passing through the door, the slide is moved to its rightward position and the door will swing closed under the action of the spring-biased hinge.

SUMMARY OF IMPACT

This is a very simple device that can be reproduced at little cost. In addition, it solves a wide-spread problem and solves it in a convenient fashion.

The client for whom it was designed is pleased with it and is making the design known to other people in wheelchairs.

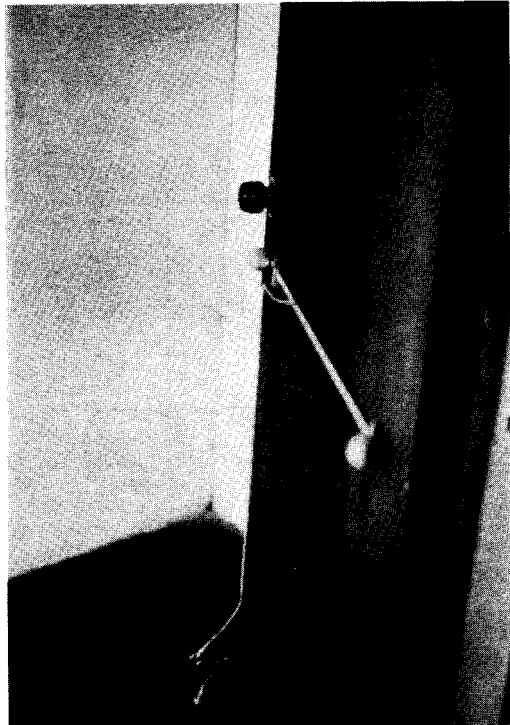

TECHNICAL DESCRIPTION

The spring-biased hinge is mounted on the back side of the door so that the axis of the hinge is **colinear** with the other hinges.

On the front side of the door is the simple mechanism shown in the photo. It consists of a pivoted door stopper with a short lever welded to it. A nylon string connects the end of the lever with the horizontal aluminum slide which moves in brackets attached to the door. The string is guided by eyelets which are placed on the door so that, as the slide is moved to the right, the door stopper is raised out of contact with the floor. This allows the door to swing closed under the action of the spring biased hinge.

When the slide is moved to the right position, the door stopper falls under gravity into contact with the floor. In this position, the door may be opened but the stopper prevents it from swinging closed. The cost of this device, not including installation, is about \$25.

"A Kinetic Toy Array"

Designers: L. Mamiya, C. Brown, S. Hernandez
Disabled Coordinator: S. Buse, Las Cruces Public Schools
Supervising Professor: R. A. Willem, Ph.D.
Mechanical Engineering Department
New Mexico State University
Las Cruces, NM 88003

INTRODUCTION

The goal of this project was to develop an array of toys to engage a handicapped child with a short attention span. It was considered desirable that the toys both involve the child motorically and produce motion, preferably of a varied or random nature.

An array of five toys were developed and combined in a single cabinet. Proceeding in a clockwise direction from the upper center, a miniature basketball toy was developed which produces five seconds of "celebration" noise each time a basket is made. Next to that is a ball-drop toy in which a ball bounces chaotically as it falls through a maze of dowels. Below that is a telephone dial which activates a line of blinking lights when it is rotated. In the lower right hand corner is a sand toy in which the colored sand and oil enclosed assumes a new configuration as the toy is rotated to a new position. Lastly, in the upper right hand corner is a toy in which colored confetti in a plexiglass box is agitated when a button is pushed. The agitation is produced by an upward current of air from a battery operated fan.

SUMMARY OF IMPACT

This array of toys was developed for a non-verbal, autistic child who is mentally handicapped. He has shown particular interest in the confetti and telephone dial toys and playing with these has helped him focus attention and develop eye contact. As this child is attention deficient, it is significant that he will spend in the neighborhood of a minute playing with these toys. Other handicapped children in his class have also had fun with these toys.

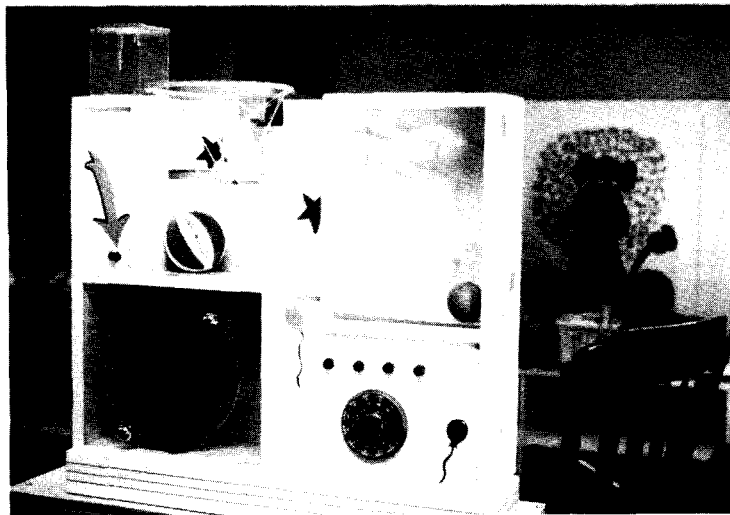

TECHNICAL DESCRIPTION

The dimensions of this array is approximately 3 x 3 x 1 ft. and weighs 30 to 40 lbs. It may be used on the floor or placed on a table top. The back of the cabinet is removable which must be done to replace the 12 volt battery which powers the telephone dial lights and the fan of the confetti toy or the two AAA batteries powering the noise maker. The cost of making this device is approximately \$500.

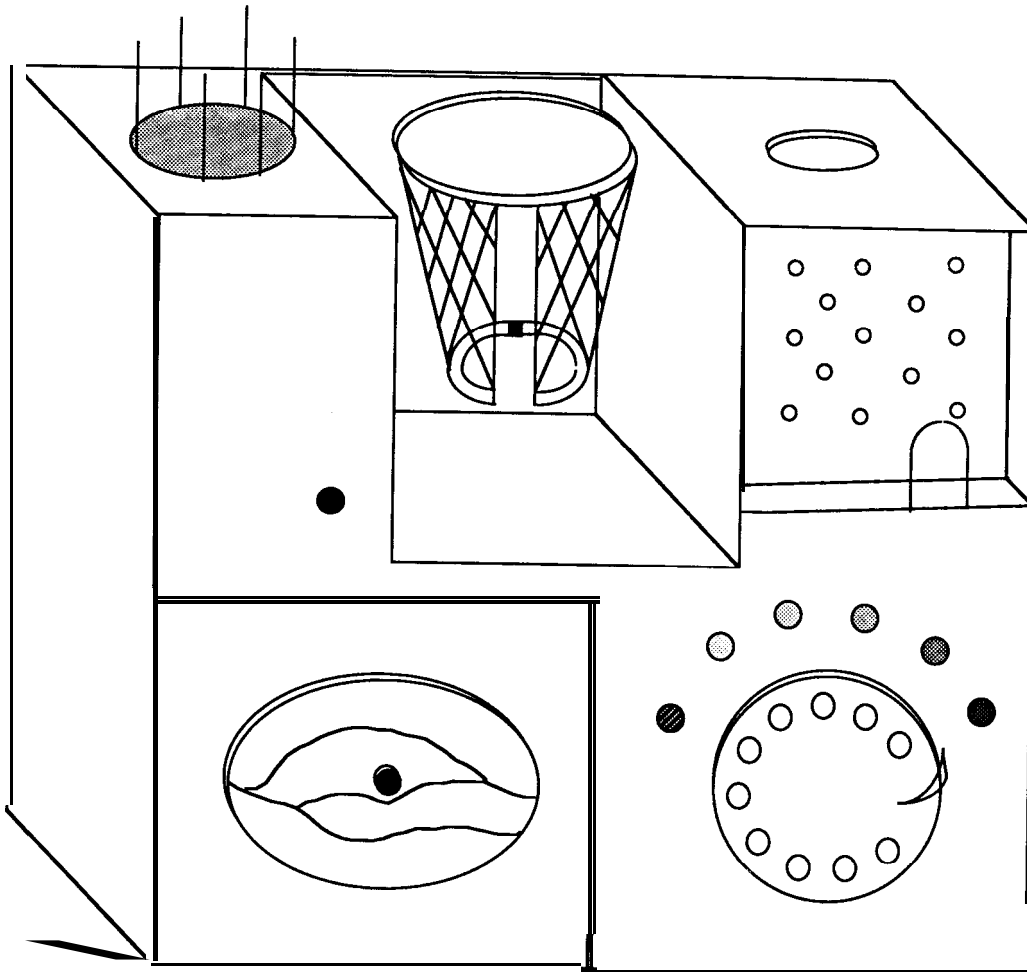

"Basic Communication Device"

Designers: J. Corelis, S. Daugherty, B. Sawaged
Disabled Coordinator: K. Carlson, Las Cruces Public Schools
Supervising Professor: R. A. Willem, Ph.D.
Mechanical Engineering Department
New Mexico State University
Las Cruces, NM 88003

INTRODUCTION

The outcome of this project was to produce a basic communication device operated orally in which a sip produces an audible "yes" while a puff produces an audible "no." The primary challenge was to do this at a low cost while producing a relatively compact, battery-operated device.

The unit has an adjustable goose-neck with a sip and puff straw at its end which the operator holds in his mouth. The straw is connected by a flexible plastic tubing to the pneumatic switch housed in a metal box. The metal box also houses the electronics of the unit. A soft carrying case accommodates the total unit.

SUMMARY OF IMPACT

The recipient of this device is a young boy who has severe cerebral palsy and, in addition, is mentally retarded and blind. He has no speech but is capable of making some vocal sounds.

The child has been able to operate the sip part of the device but has yet to produce the puff response. Due to the severe condition of the child and his naturally low level of motivation, an extended period will be needed to work with the child in the use of this communication tool. The device, however, appears to be well suited to the disabilities of the child.



TECHNICAL DESCRIPTION

The schematic below shows how the various components comprising the unit are interconnected. The pneumatic switch and goose-neck were purchased from Prenke Romich Co.' (model PS-2). The two delay timers were purchased from Steven E. Kanor, Ph.D., Inc. of Hastings, NY (model 00600). Either one or other of the delay timers is momentarily switched by a sip or puff to the pneumatic switch. That delay timer, under the action of the momentary pneumatic switch closure, closes another switch for a preset period of time (up to 30 seconds) which activates the cassette recorder connected to it. Each cassette player has a continuous loop tape, one with "no" and the other with "yes" recorded at intervals. Depending on which recorder is activated a "no" or "yes" comes out over the speaker.

The schematic does not show a double pole double throw switch which switches the power to both timers, a small 9 volt battery in each timer. The cassette players are the kind used to power ear-phones and are operated by two AA batteries in each. The cost of making this unit is \$450.

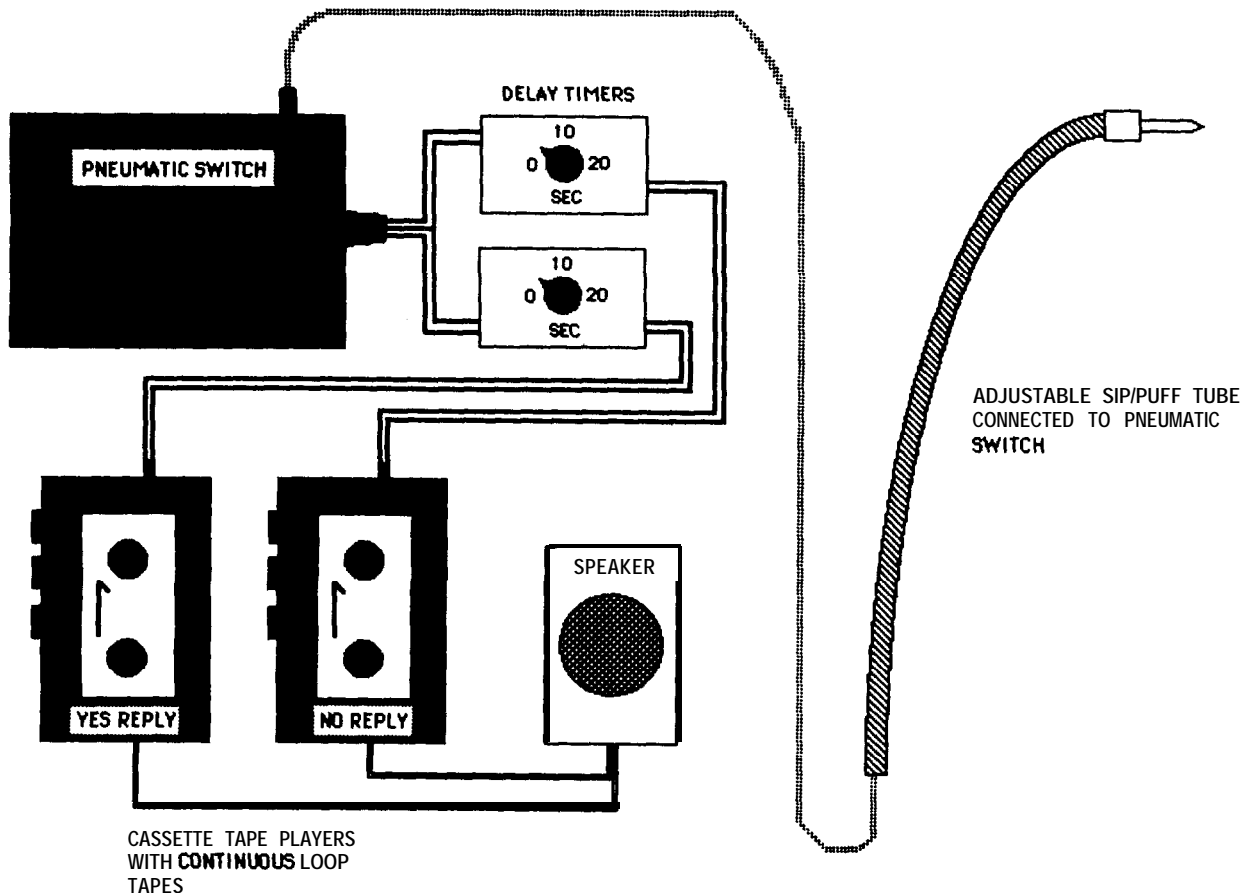

"Walker/Stabilizer"

Designers: J. Buntain, A. Martinez, D. Pruitt
Handicapped Coordinator: L. Anfinson, Las Cruces Public Schools
Supervising Professor: R. A. Willem, Ph.D.
Mechanical Engineering Department
New Mexico State University
Las Cruces, NM 88003

INTRODUCTION

This modified walker aids a child without balance control to practice controlled, arm extended, balanced movement. The walker used in this project was purchased and then adapted to the specific need.

The objective in this case was to develop a device which promotes a forward leaning posture and a controlled resistance to forward movement while providing adequate lateral stability and **constraint**.

SUMMARY OF IMPACT

The child for whom this walker was developed has severe cerebral palsy, is ataxic (poor balance and motion control) and has slight mental retardation. He is four years old, verbal, happy, and excited about having a walker.

He has taken to using the walker with enthusiasm. Presently, it is used as therapy device with the wheel brakes partially set to provide some pushing resistance.

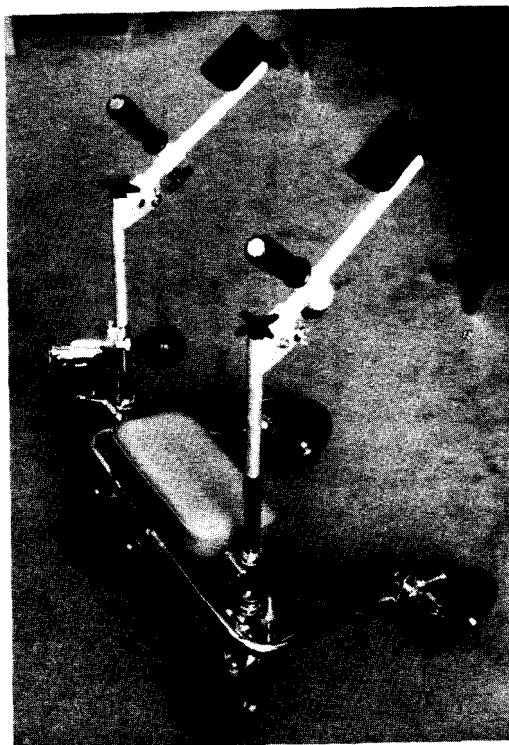

TECHNICAL DESCRIPTION

The basic walker which was modified is the product of Ortho-Kinetics and is model #6283. The name given to this model is "Jungman".

The modification involves replacing the standard walker "handles", which attach to the verticle tubes of the walker, with the "handles" shown below. These handles provide the interface between the walker and the child. They have seven degrees of adjustment:

- a vertical displacement and angular displacement with respect to the walker
- the arm support bar can be adjusted linearly and rotationally
- the hand grip can be adjusted linearly and rotationally
- the hand-grip/arm-supported bar can be **adjusted angularly.**

The walker was purchased used and cost \$180. The fabrication of the modified parts cost \$550.

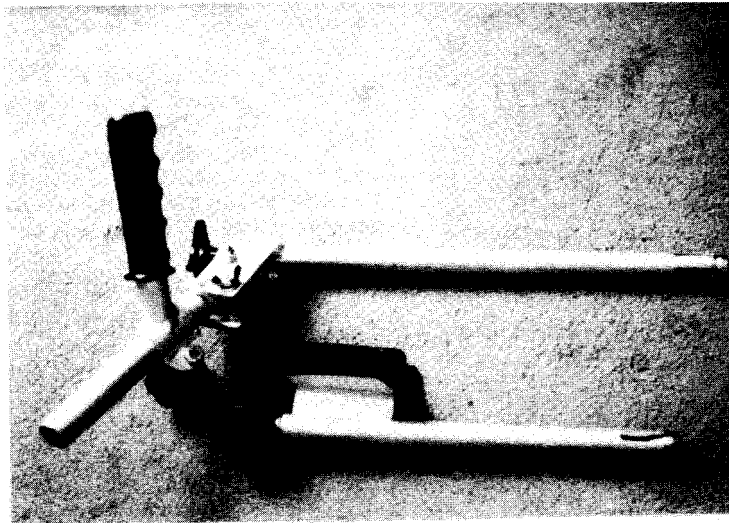

"Page Turner"

Designers: S. Boyd, G. Gallegos, C. Martinez
Handicapped Coordinator: S. Watson, New Vistas Center
Supervising Professor: R. A. Willem, Ph.D.
Mechanical Engineering Department
New Mexico State University
Las Cruces, NM 88003

INTRODUCTION

The intent in this project was to develop a device that would assist a woman who has partial arm mobility but virtually no finger mobility **to turn pages. It is truly an assistive device** in that it relies on the user's **power. It is an interface** which takes the limited unsteady **motion** of the user and converts it into **motion to turn the page** of a magazine or book.

To use the device, the user places their hand on the slide which is guided by the crossways brass bar. The slide not only translates but also rotates on the bar. Attached to the slide is a long projection with a rubber eraser on the end. It is the eraser which contacts the paper. To move the eraser out of contact with a page **simply** requires that the slide be rotated to move the eraser upward. The eraser, in or out of contact with a page, is translated side to side by translating **the** slide.

Either a left or right handed user can be accommodated by adjusting the brackets holding the bar to the frame. The frame is made of wood and has **plastic** clamps to hold the book in position.

SUMMARY OF IMPACT

The recipient of this device is a head-injured woman of **27** years old who has suffered considerable **motor impairment as a result** of her injury, cannot speak, but appears to have suffered little or no mental **impairment. Her** limited arm and hand movement is **sufficient** to permit her to operate a device of this kind.

The recipient made use of the device for some matter of weeks, however, the design was not sufficiently robust to withstand long use. It failed to maintain the eraser in its proper position and also one of the brass rail supports fractured. It is anticipated that another student design group will resume development of this very practical and important device in the next school term.

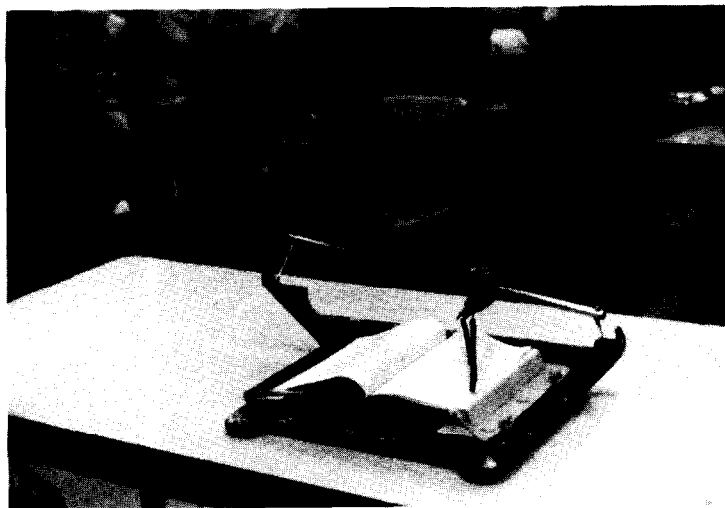

TECHNICAL DESCRIPTION

This device was fabricated directly from sketches; therefore, the most useful documentation is likely photographs and the description of its operation given in the Introduction.

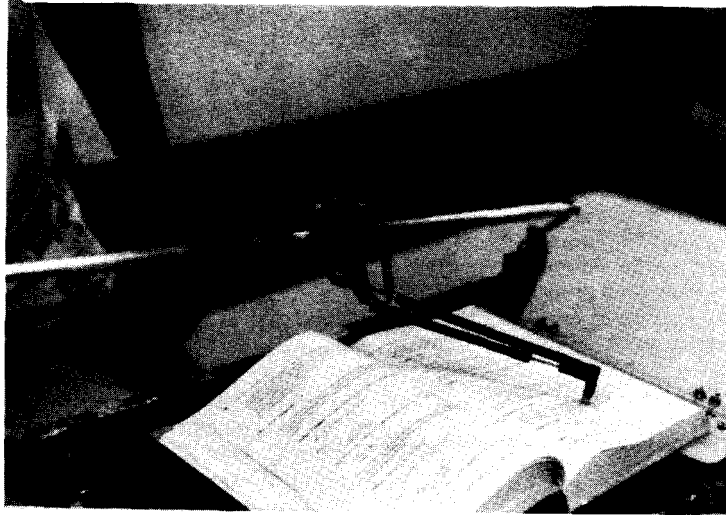

"Oven Temperature Setting Assistive Device for the Visually Impaired"

Designers: K. Nix, G. Silversmith, E. Manzanares
Handicapped Coordinator: M. Ruddy, New Vistas Center
Supervising Professor: R. A. Willem, Ph.D.
Mechanical Engineering Department
New Mexico State University
Las Cruces, NM 88003

INTRODUCTION

Since a blind person is unable to see the numbers on the oven temperature control dial, another means must be used to make this setting. In this project a device has been designed and made which gives an audible indication of the temperature setting of an oven and it appears to be suitable for use on most ovens.

When installed on the oven for which it was specifically designed, the device makes a clicking sound for every 25° degrees of temperature increase or decrease.

SUMMARY OF IMPACT

This device was made for a young blind man with an M.S. in counseling.

He counsels the handicapped, particularly those with sight impairments. It is installed on the oven control in the kitchen of his apartment.

The device works to the client's total satisfaction and allows him to make use of his oven for things requiring accurate temperature control. Also, because of his professional work, he can make others aware that this kind of device is possible.



TECHNICAL DESCRIPTION

The device has three major parts: the clicker arm, aluminum gear, and steel sleeve. The steel sleeve is pressed into the aluminum gear and four equally spaced radial holes are drilled and tapped to accommodate four 6-32 set screws. The clicker arm rotates freely on the steel sleeve and is maintained on the sleeve by the steel retaining ring. The spring loaded ball in the clicker arm engages the teeth of the aluminum gear and it is the sound of the ball moving over the teeth that produces the clicking sound.

The device is installed by first removing the oven temperature dial and then placing the steel sleeve of the assembled device over the oven dial shaft so that the retaining ring faces out. Then the four set screws are tightened on the shaft so that the shaft lies as near to the center of the sleeve as can be achieved by eye. Then the head of the clicker arm is attached to the vertical front surface of the stove with epoxy or some strong adhesive. Finally, the oven dial is replaced and the device is ready for use.

The cost of the device is about \$35 not including machining.

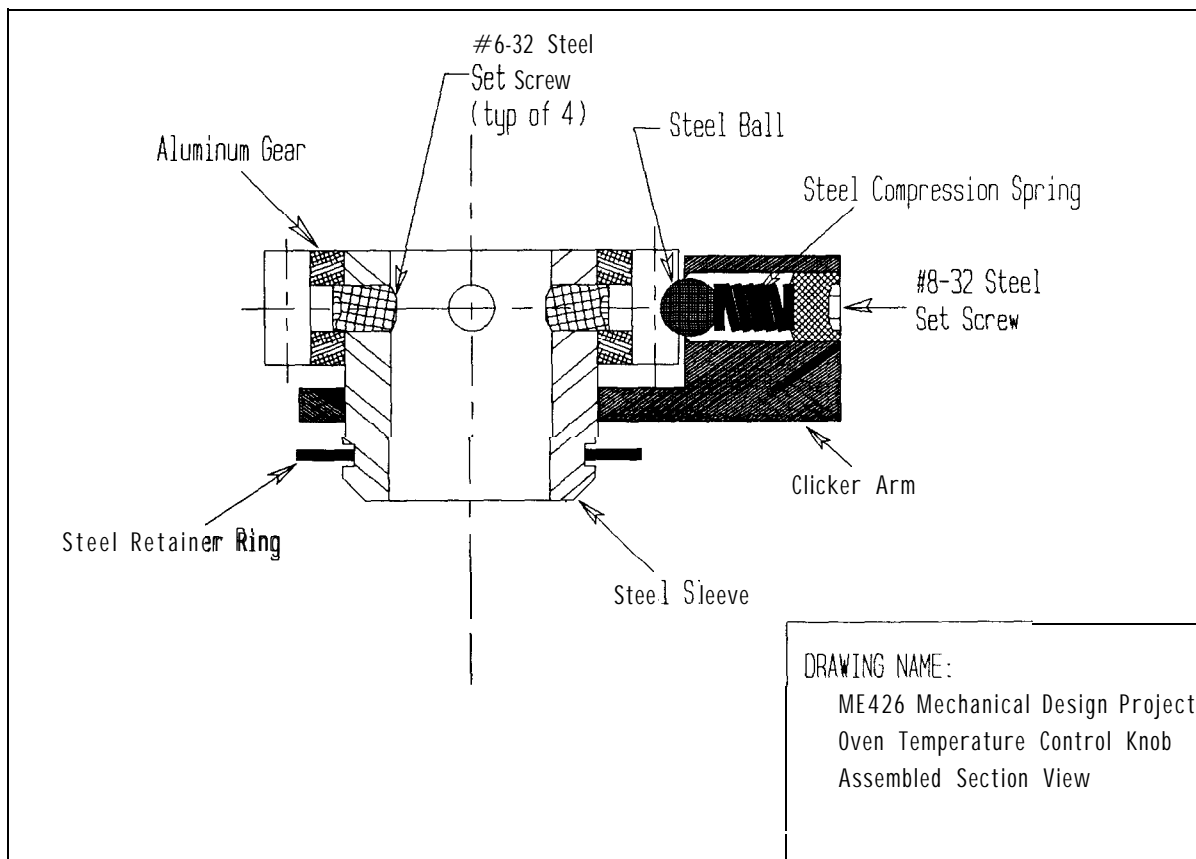

"Measuring Device for the Visually Impaired"

Designers: C. Ober, B. Pete, D. Jaycox
Handicapped Coordinator: M. Ruddy, New Vistas Center
Supervising Professor: R. A. Willem, Ph.D.
Mechanical Engineering Department
New Mexico State University
Las Cruces, NM 88003

INTRODUCTION

The device developed in this project allows a visually impaired person to make liquid and dry measurements conveniently in a kitchen setting. This device will measure a half cup of either liquid or dry material each time it is operated.

The device is used by pouring either liquid or dry powder into the funnel sufficient to fill it more than half way. Then the device is picked up by the handle with one hand and held over the container the material will be measured into. The other hand is used to rotate the piece of rigid plastic tubing suspended at top and bottom by the two elastomer valves. Each time the plastic tube is rotated through approximately a half revolution backward and forward about its vertical axis, a half cup of material will fall through the metering column.

When the measuring is done, any excess material remaining in the funnel may be poured back into its storage container. The funnel may be cleaned easily by rotating the plastic ring attached to the frame at the bottom until both valves are open simultaneously (this can be determined by touch) and running water through it.

SUMMARY OF IMPACT

The client in this case is a counselor of the handicapped, particularly those with vision impairments and he himself is blind. There appear to be two difficulties with this device. The first is that it does not address a large need for the sight impaired. The second problem is that to use this device for its intended function is no easier and, perhaps, somewhat more cumbersome than to do it without using specialized means.



TECHNICAL DESCRIPTION

This measuring device has a wooden frame of which the handle is part. Attached to the top of the frame is a wide-mouth funnel and at the bottom of the frame coaxial with the funnel is a short length of rigid plastic tube. The plastic tube has a flange that prevents it being pulled up through a hole in the frame base. A longer length of the same rigid plastic tube constitutes the control volume in the measuring column. It is suspended between the lower opening of the funnel and the upper opening of the piece of plastic tube in the base by two elastomeric valves which resemble thick sausage casing. A suitable material for the valves has been difficult to find. Sections of fingers from unlined rubber gloves is the best material which has been found to date.

The approximate cost of making this device is about \$15.

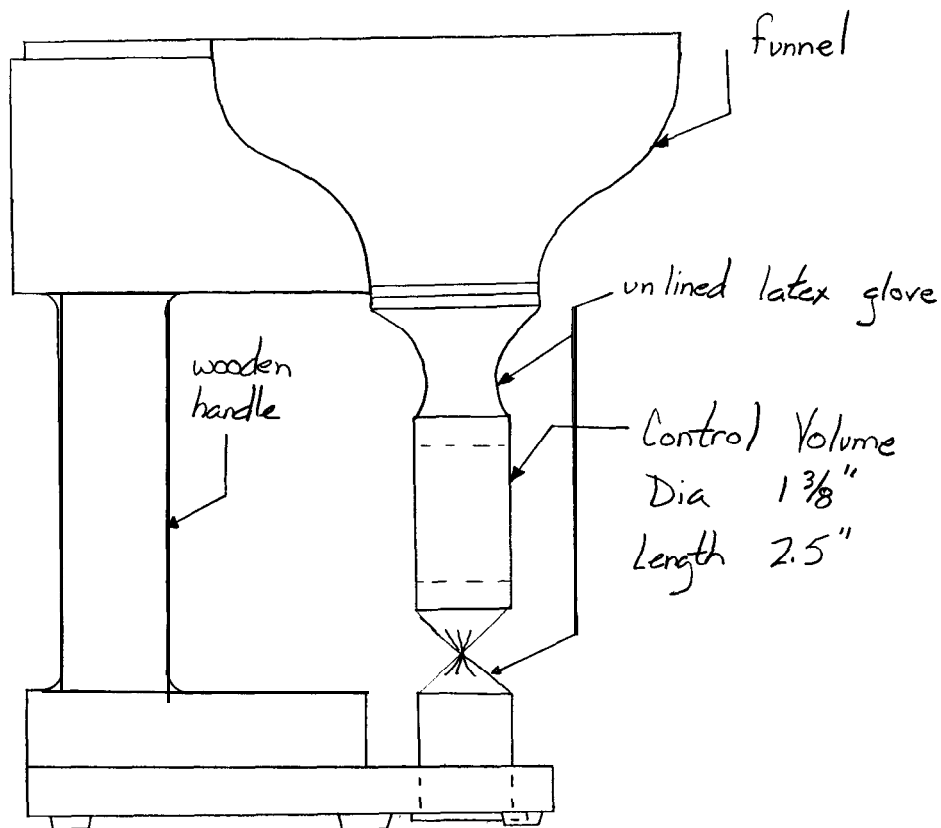

"Jar Opener"

Designers: D. Turnbull
Supervising Professor: R. A. Willem, Ph.D.
Mechanical Engineering Department
New Mexico State University
Las Cruces, NM 88003

INTRODUCTION

Jars with screw-on lids can be difficult to open, particularly for the elderly or others who due to injury have reduced upper body strength. The outcome of this project was the development of a device for opening jar lids.

This device makes use of the same principle for gripping a jar and lid that is used in a pipe wrenches. To use it, a jar is set on the base and the jaws of the stationary gripping unit are adjusted to grip the jar in the vicinity of its bottom. Then the movable gripping unit is adjusted to grip the lid and then using the wood handles, a torque is applied to loosen the lid.

A feature of this device is that a very large torque can be applied to the lid with relative ease. The rubber inserts in the lower grip holds a glass jar well, however, the upper (movable) grip which has tooth inserts made of aluminum was found to slip in some instances on painted metal caps.

The base is designed so that it can be placed on the edge of a counter or table top and it can also be set in the lap of someone in a wheelchair (the semi-circular cutouts are intended to fit over the user's thighs).

SUMMARY OF IMPACT

The client for this device is a frail elderly woman who lives alone. She makes occasional use of the device, however, it is somewhat large, hard to store, and expensive for its intended function.

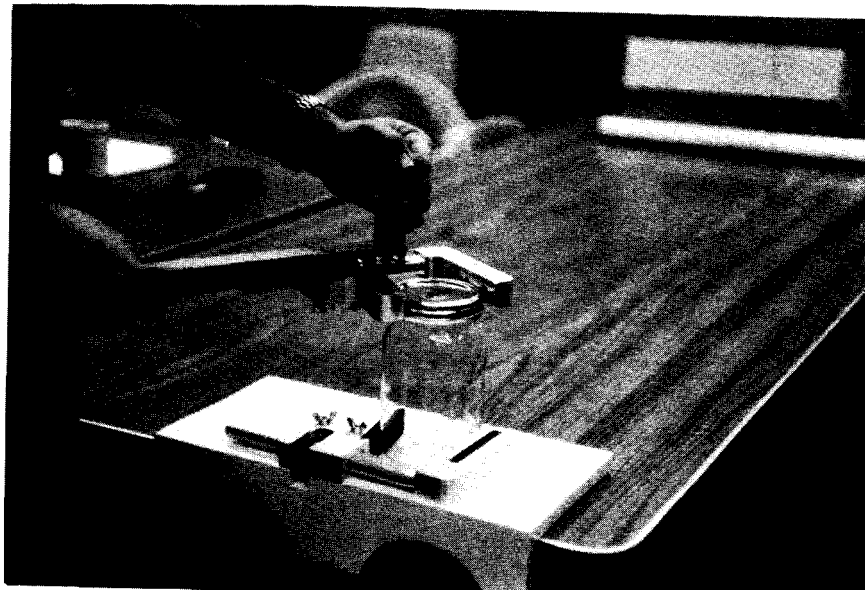

TECHNICAL DESCRIPTION

The detail drawings describing this device were made in full detail. They are too large to be reduced to a single small page. That-being the case, photographs are the best means of **description**. If there is further interest in this design, the designer can be contacted through the supervising professor. The cost of fabricating this device was approximately \$750.

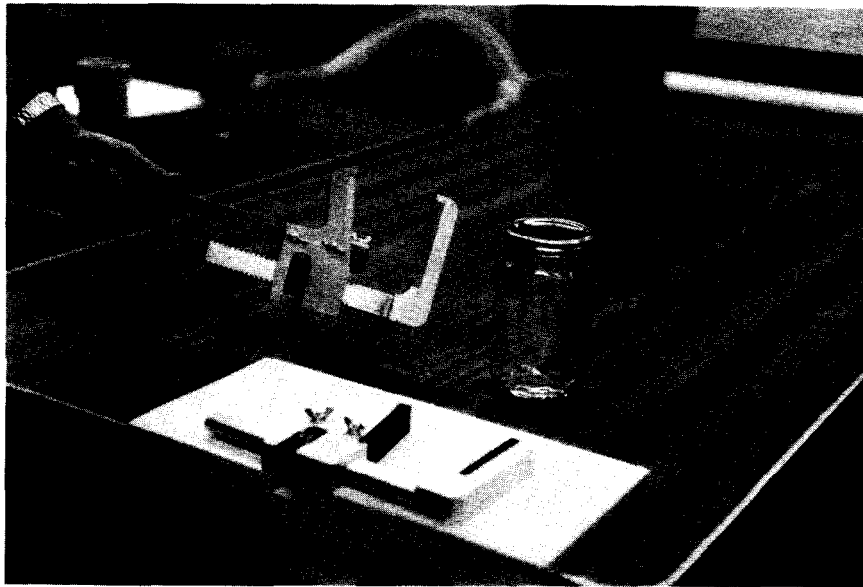



S. VALENTA